

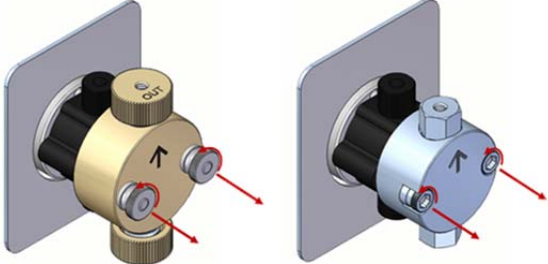
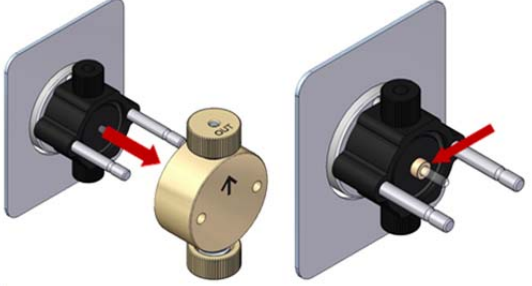

Document Number:	903117	Revision:	A
Description:	Check Valve Replacement Instructions	Date:	November 9th, 2015
		Sheet:	Page 1 of 3

REV	CHANGE DESCRIPTION	ECO #	INITIALS	DATE
A	Release	-	TF	11/9/15

1.0 Procedure

Before removing the pump head, turn OFF the pump power, and disconnect the inlet and outlet lines from the check valve housings.

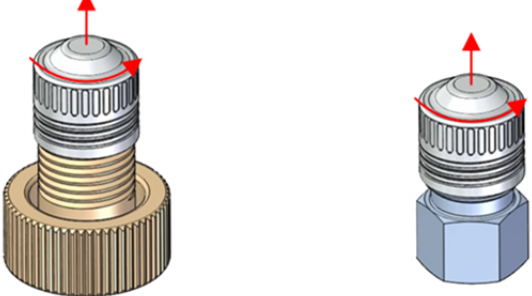
<p>Step 1</p>	<p>Remove the two pump head fasteners. Use a 3/16" hex key for recessed nuts. If necessary, use pliers for thumb nuts.</p>	
<p>Step 2</p>	<p>Carefully pull the pump head forward and off the guide pins. Keep the self-flush housing in place. Pull straight and slowly to prevent damage to the piston. Note: The back-up washer may remain on the piston. Store the washer in a safe place.</p>	
<p>Step 3</p>	<p>Remove the check valve housings, capsules and seals (stainless steel only) from the pump head. Be careful not to scratch the sealing surfaces in the pump head. If necessary, use a seal removal tool to remove the capsules and/or capsule seals from the pump head. Orient the pump head assembly as shown to avoid losing parts.</p>	
<p>Step 4</p>	<p>Locate the new check valve assemblies. Remove the protective cap. Be careful not to lose any of the components. Identify which assembly is for the inlet and outlet. Refer to the images on the following pages to help with identification.</p>	

Document Number:	903117	Revision:	A
Description:	Check Valve Replacement Instructions	Date:	November 9th, 2015
		Sheet:	Page 2 of 3

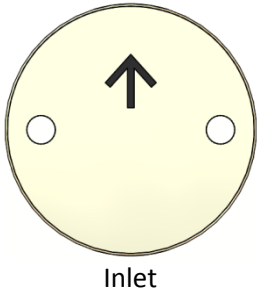
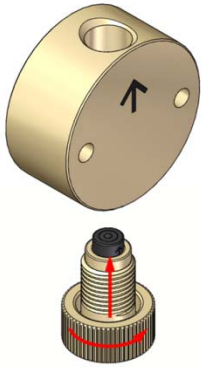
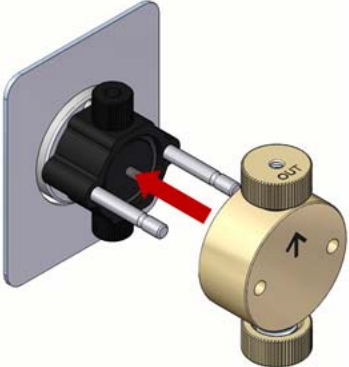
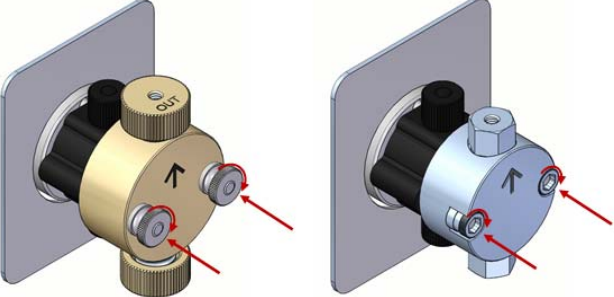
<p>Step 5</p>	<p>Determine which check valve port is for the inlet check valve assembly. If there is not an arrow on the pump head, the inlet port will have a larger through hole. If the through-holes are the same size, then the orientation does not matter.</p>	
<p>Step 6</p>	<p>Install the new inlet check valves in the inlet side of the pump head. Hold one check valve assembly as shown, and thread it into pump head until it is snug. Install the outlet check valve assembly similarly.</p> <p>Torque Specifications: Standard stainless steel: 75 in·lbs. Ultra-High Pressure: 120 in·lbs. PEEK: 12-15 in·lbs.</p>	
<p>Step 7</p>	<p>Carefully slide the new pump head into place. Push onto guide pins straight and slowly to prevent damage to the piston. Do not force the pump head into place.</p> <p>Note: Be sure the Inlet Check Valve Housing is on the bottom and the Outlet Check Valve Housing is on the top.</p>	
<p>Step 8</p>	<p>Reinstall fasteners. As you tighten, alternate side-to-side until snug. For recessed nuts, turn 1 flat past snug using a 3/16" hex key. For thumb nuts, turn 1/6 rotation past snug; if necessary, use pliers.</p>	

Document Number:	903117	Revision:	A
Description:	Check Valve Replacement Instructions	Date:	November 9th, 2015
		Sheet:	Page 3 of 3

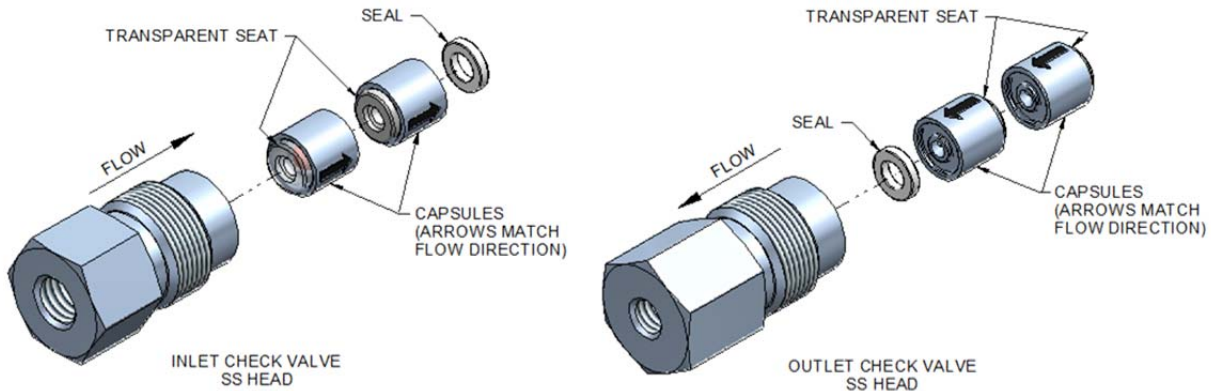

Standard Stainless Steel Check Valve Assemblies

One of each is included. The arrows on the check valves should be pointed in the same direction as the flow. The inlet housing will usually have a larger through hole. The stainless steel assemblies also include one removable Teflon seal (as shown). The seal may stick inside housing or pump head. *Torque to 75 in·lbs.*

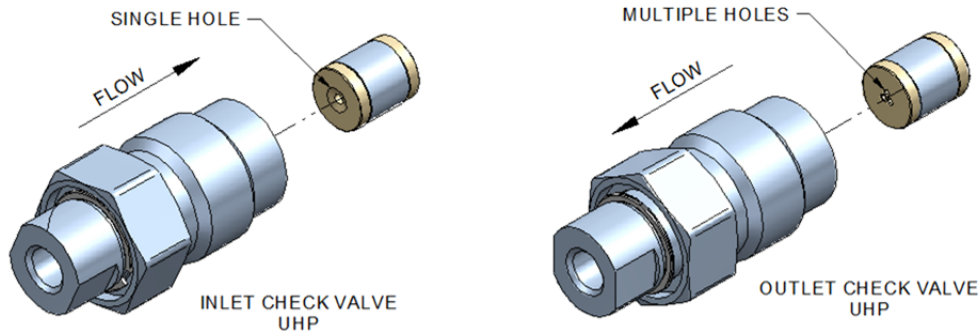

Ultra-High Pressure (18,000+ psi) Stainless Steel Check Valve Assemblies

One of each is included. Install the check valves as shown, noting the single inlet hole and multiple outlet holes. The inlet housing will usually have a larger through hole. *Torque to 120 in·lbs.*

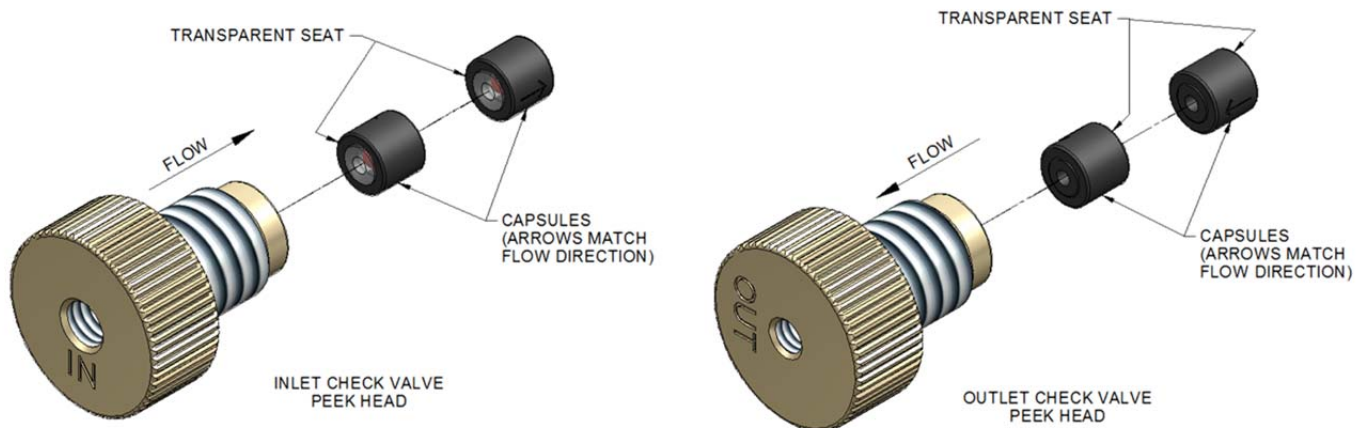

PEEK Check Valve Assemblies

One of each is included. The arrows on the check valves should be pointed in the same direction as the flow. The word "IN" or "OUT" will be present on the housing. *Torque to 12-15 in·lbs.*